



ITALIFTERS

EQUIPMENT FOR OPENING IN SAFE CONDITIONS
MANHOLE COVERS OF UNDERGROUND UTILITIES NETWORKS



GENERAL CATALOGUE



 **ITALIFTERS**
E A S Y A N D S A F E

The DOA business philosophy provides for the continuous improvement of its products. The Company reserves the right to modify the technical, functional characteristics, weights and dimensions described in this catalog at any time and without notice, for technical and commercial reasons.

INDEX

MAGNETIC COVER LIFTER LINE

XT1 NANO	Compact foldable magnetic cover lifter	6
XT3 COMPASS	Foldable double magnetic plate cover lifter	7
XT4 NANO	Magnetic cover lifter	8
CL10	Magnetic cover lifter	9
CL11	Magnetic cover lifter with curved base	10
XT1 NANO ATEX	Compact foldable opener "ATEX"	11
CL10 ATEX	Magnetic cover lifter "ATEX"	12
CL11 ATEX	Magnetic cover lifter "ATEX" for round and square lids	13
XT2	Cover lifter with separable double magnet	14
CL9	Light weight cover lifter	15
LB5	Magnetic cover lifter	16

WHEELED LEVER AND ACCESSORIES

APS90	Foldable wheeled lever	17
APS80	Light Foldable wheeled lever	18
SET OF MECHANICAL HOOKS	Set of hooks for mechanical opening	19
PM400 - PM500 - PM1000	Permanent magnets for manhole opening	20
BT95	Lifting bar to be used with wheeled lever	21
CONNECTING BRIDGE	Connecting bridge used with 2 CL10	21

COVER LIFTER LEVER

LB2	Lever for lid opener	22
LB4	Lever for lid opener	23
LB7	Small lever for lid opener	24
LB8	Lever for lid opener	25
LK70	Wheeled lever for heavy duty manhole	26
SHIMS CORNERS		27

MANHOLES OPENER "AID"

MZ120	Sliding hammer	28
T3 POLYTOOL	Multi purpose tool for lid opener	29
ES1	Screw extractor for unlocking manhole cover	30

SAFETY AND PROTECTION ACCESSORIES

AC90	Anti fall safety device for open manhole covers	31
FLEXXY	Extendable high visibility plastic safety barrier	32
SAFEGATE	High Visibility safety gate or linear	33



ITALIFTERS
E A S Y A N D S A F E

OPENING A MANHOLE QUICKLY AND SAFELY IS NO LONGER A PROBLEM!

ITALIFTERS magnetic cover lifters and his accessories, is the most modern aid in opening operations of manhole covers, grids, lids. The system is a synthesis of versatility, effectiveness, simplicity and above all, a guarantee of maximum safety!

This range of tools is built on the principle of providing small, light equipment, easily transportable even on vehicles with limited space for transporting complex and bulky equipment.

Operators knows well the problems associated with opening a manhole cover: weight to lift and possible back injuries, blockage due to asphalt, sand, rust and difficulties in repositioning it; all the above is even complicated by larger size manhole covers on the roads that often have several and complicated hooking/ locking systems on the lid.

All these problems are easily solved with the multifunctional **ITALIFTERS** line, which fit most lifting conditions and lid configurations.

ITALIFTERS lifting systems are, to all intents and purposes, the most complete, versatile, performing and easy to carry.

Top of the line in now days modern equipments



The equipment complies with rules and allows to satisfy and minimize the risks deriving from manual handling of loads as expected from Article 168 com. 2 - com. 3 of DLGS 8108 and subsequent amendments

XT1 NANO

ULTRA LIGHT FOLDING MAGNETIC MANHOLE COVER LIFTER FOR MEDIUM / HEAVY COVERS

Ultra-light, ultra-compact manhole cover lifter, ideal for quick opening of medium / heavy metallic lid of different size.



The exclusive neodymium magnets are protected by a steel sheet that prevents cracks e breakages.



*230 Kg



Incredible lifting power thanks to latest generation of neodymium magnets.



Easy to use in parallel position by two operators.



Can be used as a hooking lever in the slots for mechanical lifting.

TECHNICAL CHARACTERISTICS

Code	K0276	
Weight	Kg	2,5
Diameter of base	cm	11
Lengthen extension	cm	70
Dimension folded	cm	40 x 8 x 15
Lifting power	Kg	230 (in ideal conditions*)
Material of beak	Hardenen steel 38 NCD4	
Number and type of Magnets	7 neodymium magnets	

* Attraction force tests performed on a C36 iron base with a thickness of 18 mm. The forces of attraction can vary according to the thickness and material of the base to be lifted. Tolerance ± 5

ACCESSORIES

Shoulder pouch for XT1 NANO
Code A221013



In sturdy cordura fabric with shoulder strap ideal for transport and storage.

XT3 COMPASS

MAGNETIC COVER LIFTER WITH COMPASS STEMS

Powerful folding manhole cover with two round magnets base designed for lifting operations of cast iron manhole covers by two operators.



Lifting power up to Kg.460.



***460 Kg**



Ideal for dividing the effort by two operators.



Foldable.



Light and easy to handle



TECHNICAL CHARACTERISTICS

Code	K0437	
Weight	Kg	6
Length	cm	67
Distance between handles	cm	90
Width with stems closed	cm	24
Width with stems open	cm	43
Diameter of magnetic BASES	cm	11
Lifting power	Kg	460 (in ideal conditions*)
Number and type of Magnets	14 neodymium magnets	

* Attraction force tests performed on a C36 iron base with a thickness of 18 mm. The forces of attraction can vary according to the thickness and material of the base to be lifted. Tolerance ± 5

XT4 NANO

MAGNETIC MANHOLE COVER LIFTERS WITH EXTENDABLE HANDLE FOR MEDIUM / HEAVY LIDS

Ultra compact magnetic manhole cover lifter with extendable handle and lockable in closed or extended position by a spring button. The innovative handle is equipped with a pin for the release of cast iron covers which also allows connection with the APS80 and APS90 wheeled levers.



*300 Kg



Extendable handle



Manual lifting



Cover release with central pin

CARATTERISTICHE TECNICHE

Code	K0535	
Weight	Kg	3,5
Diameter of base	cm	14
Lengthen extension	cm	70
Dimension folded	cm	40
Lifting power	Kg	300 (in ideal conditions)
Number of Magnets		9

* Attraction force tests performed on a C36 iron base with a thickness of 18 mm. The forces of attraction can vary according to the thickness and material of the base to be lifted. Tolerance ± 5



Lifting with wheeled levers APS80 or APS90

CL10

MANUAL MAGNETIC MANHOLE LIFTER

Universal model with rectangular base suitable for lifting, moving and repositioning most of manhole covers, drains, cast iron grates and ferrous materials.



Use 1: manual Opening.



Use 2: opening with wheeled lever APS90 or APS80.



Use 3: opening with two plates in parallel position.



ACCESSORIES

Anti-magnetic protective sack **Cod. A221006**



It prevents accidental contact between the magnetic plate and metal objects and for safety transport or storage.

TECHNICAL CHARACTERISTICS

Code	K0265	
Weight	Kg	7
Base dimension	cm	21 x 16
Lengthen extension	cm	70
Retracted size	cm	55 x 16
Lifting power	Kg	400 (in ideal conditions*)
Number and type of Magnets	16 neodymium magnets	

* Attraction force tests performed on a C36 iron base with a thickness of 18 mm. The forces of attraction can vary according to the thickness and material of the base to be lifted. Tolerance ± 5

CL 1 1

CURVE-BASED MAGNETIC COVER LIFTER USABLE IN 3 DIFFERENT WAYS

Universal magnetic lifter with curved base to ensure the best magnetic adhesion on the circumference of circular manhole covers also with "filling" cast iron frame and in asphalt / stone / cement with central metal disc.



Extendable front lever that allows the right lift geometry and ensure the full strength of lift and turning of hinged lids.



Use 1: manual Opening.



Use 2: opening with wheeled lever APS90 or APS80.



Use 3: Opening with horizontally extended handle bar.

CARATTERISTICHE TECNICHE

Code	K0353	
Weight	Kg	7
Base dimension	cm	28 x 12
Lengthen extension	cm	70
Retracted size	cm	55 x 12
Lifting power	Kg	420 (in ideal conditions*)
Number and type of Magnets	18 magneti al neodimio	

* Attraction force tests performed on a C36 iron base with a thickness of 18 mm. The forces of attraction can vary according to the thickness and material of the base to be lifted. Tolerance ± 5

ACCESSORIES

Anti-magnetic protective sack **Cod. A221006**



It prevents accidental contact between the magnetic plate and metal objects and for safety transport or storage.

Ultra-light, ultra-compact manhole cover lifter, recommended for the safe lifting of gas network covers, petrol stations, petrochemical plants, docks, in potentially explosive situations.



Category 3 ATEX tools suitable for use in places classified ZONE 2.



Spark-proof metal base.



The exclusive neodymium magnets are separated and protected by a antispark sheet.

ACCESSORIES

Shoulder pouch for XT1 NANO
Code A221013



In sturdy cordura fabric with shoulder strap ideal for transport and storage.

TECHNICAL CHARACTERISTICS

Code	K0324	
Weight	Kg	2,5
Diameter of base	cm	11
Lengthen extension	cm	70
Dimension folded	cm	40 x 8 x 15
Lifting power	Kg	210 (in ideal conditions*)
Material of beak	Hardenen steel 38 NCD4	
Number and type of Magnets	7 neodymium magnets	
ATEX category/class	II3G c IIB T6 -20°C<Tamb<+50°C	

* Attraction force tests performed on a C36 iron base with a thickness of 18 mm. The forces of attraction can vary according to the thickness and material of the base to be lifted. Tolerance ± 5

CL10 ATEX

MANUAL MAGNETIC COVER LIFTER



Universal manhole cover with rectangular base usable in 4 different modes, suitable for lifting, moving and repositioning most of manhole covers and drains, in ATEX areas.



Category 3 ATEX tools suitable for use in places classified ZONE 2.



Spark-proof metal base.



TECHNICAL CHARACTERISTICS

Code	K0325	
Weight	Kg	7
Base dimension	cm	21 x 16
Lengthen extension	cm	70
Retracted size	cm	55 x 16
Lifting power	Kg	380 (in ideal conditions*)
Number and type of Magnets	16 neodymium magnets	
ATEX category/class	II3G c IIBT6 -20°C<Tamb<+50°C	

* Attraction force tests performed on a C36 iron base with a thickness of 18 mm. The forces of attraction can vary according to the thickness and material of the base to be lifted. Tolerance ± 5

ACCESSORIES

Anti-magnetic protective sack **Cod. A221006**



It prevents accidental contact between the magnetic plate and metal objects and for safety transport or storage.



CL11 ATEX

MAGNETIC COVER LIFTER FOR ROUND AND SQUARE LIDS

Universal manhole cover for round, hinged or square manhole covers, usable in 4 different ways, suitable for lifting moving and repositioning most of manhole covers, drains, in ATEX areas.



Suitable for round cover/lid.



Spark-proof metal base.



Extendable front lever that allows the right lift geometry and ensure the full strength in lifting and turning upside down of hinged lids.

ACCESSORIES

Anti-magnetic protective sack **Cod. A221006**



It prevents accidental contact between the magnetic plate and metal objects and for safety transport or storage.



CARATTERISTICHE TECNICHE

Code	K0326	
Weight	Kg	7
Base dimension	cm	21 x 16
Lengthen extension	cm	70
Retracted size	cm	55 x 16
Lifting power	Kg	400 (in ideal conditions*)
Number and type of Magnets	16 neodymium magnets	
ATEX category/class	II3G c IIB T6 -20°C<Tamb<+50°C	

* Attraction force tests performed on a C36 iron base with a thickness of 18 mm. The forces of attraction can vary according to the thickness and material of the base to be lifted. Tolerance ± 5

XT2

COVER LIFTER WITH DOUBLE SEPARABLE MAGNETS

Powerful manhole cover lifter with two round magnets designed for operations with one or two operators. XT2 can be quickly separated into two tools to use as a single operator job or with two operators in two different job site.



*460 Kg



Used with single operator.



Used with two operators in parallel with divided tool.



Useful for dividing the effort between two operators in complete safety.



TECHNICAL CHARACTERISTICS

Code	K0436	
Weight	Kg	5
Height	cm	70
Width	cm	40
Diameter of magnetic base	cm	11
Lifting power	Kg	460 (in ideal conditions*)
Number and type of Magnets	14 neodymium magnets	

* Attraction force tests performed on a C36 iron base with a thickness of 18 mm. The forces of attraction can vary according to the thickness and material of the base to be lifted. Tolerance ± 5



Magnetic cover lifter model CL9 designed for the manual lifting of medium / light weight metal lids. Lightness and easy handling of the tool allow easy transport to the job site.



Lifting capacity up to Kg. 230.



Opening manually light/middle weight lid.



Ergonomic handle.



ACCESSORIES

Anti-magnetic protective sack **Cod. A221006**



It prevents accidental contact between the magnetic plate and metal objects and for safety transport or storage.

TECHNICAL CHARACTERISTICS

Code	K0410	
Weight	Kg	4
Dimension	cm	12 x 12,5
Length	cm	50
Lifting power	Kg	230 (in ideal conditions*)
Number and type of Magnets	9 neodymium magnets	

* Attraction force tests performed on a C36 iron base with a thickness of 18 mm. The forces of attraction can vary according to the thickness and material of the base to be lifted. Tolerance ± 5

LB5

ULTRA LIGHT MAGNETIC MANHOLE OPENER

Ultra light magnetic manhole covers opener for operations on medium light lids, equipped with a "T" handle that can be used as a mechanical lever in case of absence of magnetic adhesion. The compact size of the LB5 allows easy transport and storage of the equipment.



Lifting capacity up to Kg. 70.



Folding base to facilitate the use and storage of the tool.



The T-handle can be used as a lifting hook.

TECHNICAL CHARACTERISTICS

Code	K0361	
Weight	Kg	2
Length	cm	65
Dimension of magnetic base	cm	8 x 4
Lifting power	Kg	70 (in ideal conditions*)
Number and type of Magnets	5 neodymium magnets	

* Attraction force tests performed on a C36 iron base with a thickness of 18 mm. The forces of attraction can vary according to the thickness and material of the base to be lifted. Tolerance ± 5

APS90

WHEELED FOLDING LEVER

Versatile wheeled folding lever, designed for use with DOA cover lifters and their accessories in demanding operations and opening of heavy manhole covers with minimum effort and maximum safety.



Use 1: magnetic opening with single CL10 or CL1.



Use 2: opening with two CL10 in parallel joined with connecting "bridge" on heavy lid.



Use 3: mechanical opening with locking clamps.



Use 4: magnetic opening with magnet permanent (PM400 or PM500) for very heavy manhole cover.



Use 5: mechanical opening with **BT9** ITALIFTERS bar.



Extendable and tilting upper handle.

TECHNICAL CHARACTERISTICS

Code	K0262	
Weight	Kg	10
Long lever length retracted / extended	cm	97 / 160
Short lever length retracted / extended	cm	40 / 56
Lifting weight	Kg	600

APS80

WHEELED FOLDING LEVER

Extendable and tilting upper handle. Lightened and simplified version of the APS90. Ideal for opening manhole covers that have lifting problems, in difficult operations and opening of heavy manhole covers with minimum effort and maximum safety.



Use 1: opening with magnetic CL9 - CL10 - CL11.



Use 2: combination APS80 and Permanent magnet PM400 or PM500.



Use 3: combination APS80 with mechanical clamp and hooks set

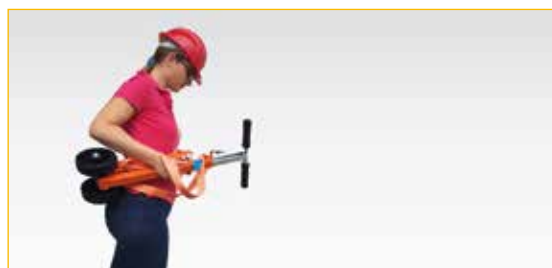

Foldable, extremely compact and light weight, easily transportable.

TECHNICAL CHARACTERISTICS

Code	K0363	
Weight	Kg	7
Upper lever length retracted	cm	75
Extended upper lever length	cm	110
Lower lever length	cm	40
Lifting weight	Kg	600

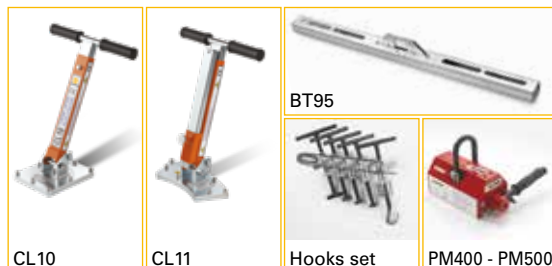

Accessories for APS90 and APS80.

SET OF MECHANICAL HOOKS

HOOKS FOR THE MECHANICAL OPENING OF MANHOLES WITH WHEELED LEVERS APS90 and APS80

Hook set consisting of four wing clamps and one hook clamp intended for use in combination with folding levers APS90 - APS80 for opening / moving / repositioning of manhole covers and where is not possible to use a magnetic opener.



Suitable for mechanical opening of manhole covers.



Phase 1: set the hook central bar in the position that can be hooked up by the APS90/APS80.



Phase 2: engagement of the lever in the clamp.



To be used with both **APS90** or **APS80**

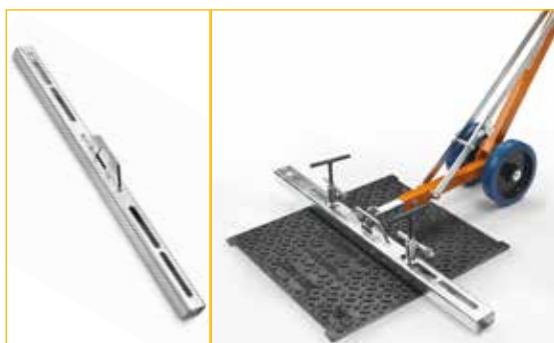

Use with two clamps in combination with the lifting transversal BAR **BT95**.

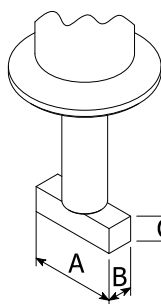

TECHNICAL CHARACTERISTICS

Code	Dimensions			
		A	B	C
D901250	mm	50	10	10
D901252	mm	27	10	10
D901251	mm	27	8	8
D901253	mm	27	8	8

PM400 - PM500 - PM1000

PERMANENT MAGNET COVER LIFTER

Powerful magnets to be used in combination with folding levers APS90 - APS80, with trolley LK70, with mini excavators and cranes, for lifting very heavy ferrous manhole covers.



Use 1: necessary use in the presence of manhole covers excessively heavy or worn out.



Shown in picture **PM500** lifting a steel plate weighing 300 Kg.



PM500 - PM1000 can be used with mini excavators and cranes.



Substantial increasing of lifting power.

TECHNICAL CHARACTERISTICS

Model	Code	Weight	Dimensions (L x P x H)	Lifting weight*
		Kg	cm	Kg
PM400	K0458	9	20 x 9 x 9	400 (1200**)
PM500	K0360	18	21 x 12 x 12	500 (1500**)
PM1000	K0461	40	27 x 15 x 14	1000 (3000**)

* Attraction force tests performed on a C36 iron base with a thickness of 18 mm. The attraction forces may vary according to the thickness and material of the base to be lifted. Tolerance $\pm 5\%$.

** The declared lifting force is, for a safety factor, only a third of that resulting from the test of strength carried out. The magnets are industrial type whose lifting force has a triple safety margin of the weight of recommended lifting. ITALIFTERS magnets are to be used only for lifting manhole covers and the lifting height must never be greater than 30 cm from the road surface.



BT95

LIFTING BARTO BE USED WITH WHEELED LEVERS

Sturdy crossbar with slots for center distance adjustment and locking of hooks terminals, to be use with APS 90, APS80.



Use in combination with **mechanical locking clamps** (Cod. K0263) and **APS90** or **APS80** lever.



TECHNICAL CHARACTERISTICS

Code	K0279	
Weight	Kg	5
Length	cm	98
Slot distance capacity	cm	40 - 92

CONNECTION BRIDGE

CONNECTION BRIDGE TO BE USED WITH TWO MAGNETIC LIFTERS CL10

Connection bridge is used to "connect" two CL10 in parallel position to double the magnetic force to be use with wheeled levers APS80 and APS90.



Shown in picture the wheeled lever engaged with two **CL10** connected by the "bridge".



LB2

COVER LIFTER LEVER

Practical lever lifter for lids with latches or in the absence of cast iron surface. For the correct connection the lower hook is inserted into the slots on the cover and the lever is turned through 90°.



Inserting the hook into the slot and rotate to 90°.



In the opening operation, the length of the lever limits the operator effort.



Possibility to custom hooks according to specifications if needed.

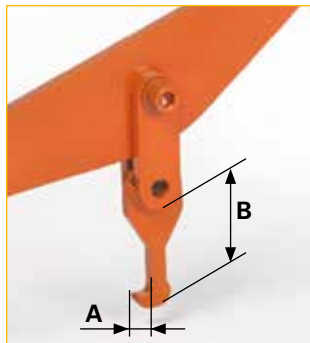

Dimension of **A** and **B** can be adapted as needed.



Opening larger lid can be done with two LB2.

TECHNICAL CHARACTERISTICS

Code		K0384
Weight	Kg	5
Lenght	cm	110
Construction material		Steel 38 NCD4



Practical and versatile tool designed to hook, lift and move all types of manhole covers, drains and grids. Maintenance for water, gas, sewers, telecommunications.



The particular angle of the lever allows an ideal ergonomics for standing operators.



Robust and durable tool, fully galvanized.



The hard plastic handles ensure perfect grip.



The "Nail" can also be used for cleaning the manhole frame from fouling and as a strong scourer inside the frame.



The "Nail" is laser cut steel, it is shaped to hook in the best way the manhole covers slot with greater strength and durability during lifting operations.

The lower end is made of solid steel that can be used to beat the cover when it's blocked.

TECHNICAL CHARACTERISTICS

Code	K0359	
Weight	Kg	2,5
Length	cm	120

LB7

LIGHT COVER LIFTER "BEAK" TYPE

Ideal for opening and repositioning manhole covers and grids of medium / small weight. The double flat beak with its hardened steel tip can be inserted in the contact slots, resistant and strong tool.



The beaks can also be used in the operations of scraping the frame of the lid.



The "D" shaped handle provides a fulcrum point to facilitate the lifting operation.



The plastic handles guarantee excellent grip even with safety gloves.



Due to its characteristics and function, it is the ideal alternative to using the classic pickaxe like in the past.

TECHNICAL CHARACTERISTICS

Code	K0266	
Weight	Kg	1,2
Length	cm	75



Built in tempered 38NCD4 steel with galvanized anti rust finish which makes the LB7 a resistant and robust tool.

LB8

COVER LIFTER LEVER

LB8 is a sturdy lever / handle that is fixed to the manhole through adjustable external struts and a central tie rod with rotating and sliding hook that are engaged in the lid slot.



Adjustable side strut to ensure support for any surface.



Central tie rod with rotating and sliding hook. In central picture visible female coupling.



Very robust, resistant to rust and over usage.

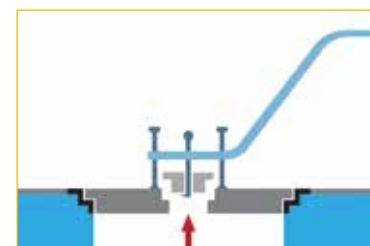
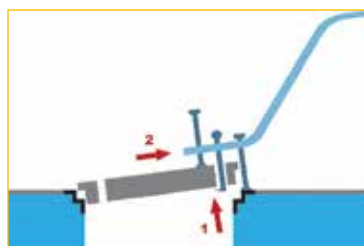
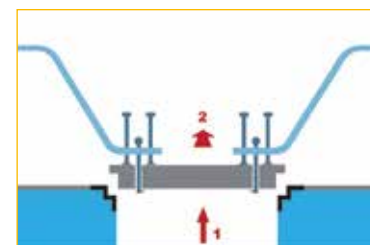
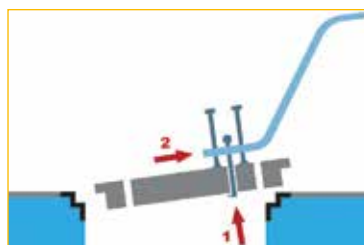

TECHNICAL CHARACTERISTICS

Code	K0267
Weight	Kg 4,5
Length	cm 100

LK70

WHEELED LEVER FOR LIFTING HEAVY COVERS

Wheeled lever for lifting very heavy and/or blocked cast iron covers using two PM 400 - 500 or 1000 in parallel or in special configuration two mechanical hooks.



Completely decomposable to facilitate storage and transport. Composed of: central column, two hooks and two sliding wheels and lever.



Adjustable lower strut for greater stability and a better control of the whole set.



It can also be customized on specific requests. Ask DOA for infos.

TECHNICAL CHARACTERISTICS

Code	K0395	
Weight of the kart group completely assembled	Kg	21
Weight of magnets	Kg	18
Magnet lifting force	Kg	500 cad.
Dimension between wheels	cm	130



It can be use with two **PM500** permanent magnet combined.

SHIMS CORNERS

SOUNDPROOF SHIMS

Special plastic soundproofing shims designed with a particular non-symmetrical configuration and a thin wedged shaped surface- studied to stop the movement of the lid and avoid the noise from flapping (code K0366).



Shims positioning between cover and frame.

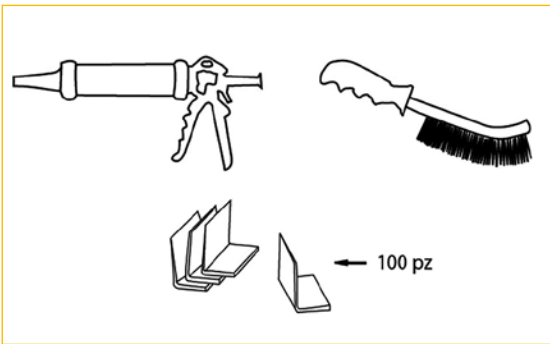

Complete set of special glue, cutter, spatula and brush for surface cleaning (Sold separately)

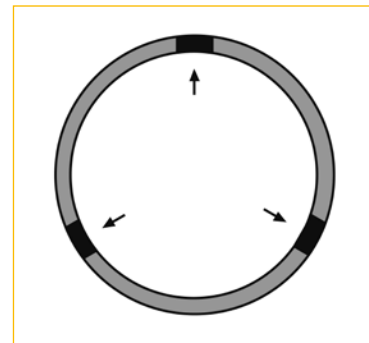
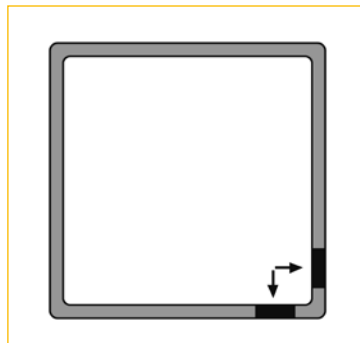
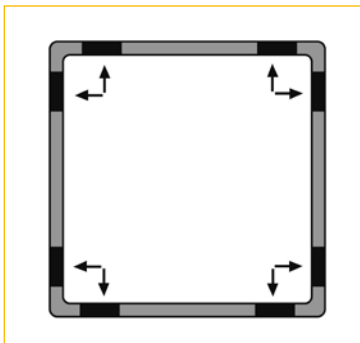

The shape of the shims ensures versatile use, suitable for manhole covers of many type. The shims avoids any banging noise of manholes of any shape and size.



Shims installation.

MZ 120

SLIDING HUMMER FOR QUICK REMOVAL OF ENCRUSTATION

Practical and versatile percussive tool designed to facilitate the opening of manhole covers blocked by rust, ice, stones, asphalt, temperature expansion and inactivity.



Safety pin when hammer is not in use.



The ergonomics of the **MZ120** allows the use of the tool in standing up position and its conical tip made in tempered steel guarantees durability and robustness.

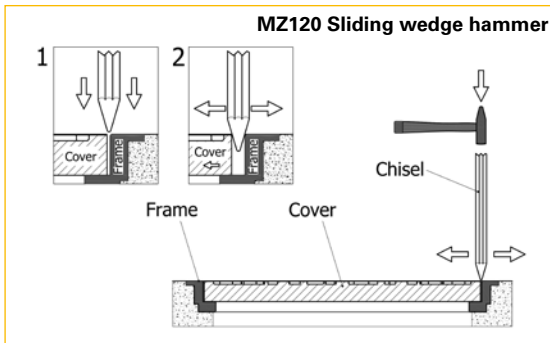

MZ120 particular shape allows you to unlock the safety lock of the lids and, subsequently, to be used as a lifting lever.

TECHNICAL CHARACTERISTICS

Code	K0352	
Weight	Kg	8
Length	cm	130



Useful for cutting layers of asphalt and concrete, cleaning and peeling dirt, which often cover the surface and the frame of the lid.

T3 POLYTOOL

TOOL FOR OPENING COVERS AND MANHOLES

Multifunctional tool designed to carry out the necessary operations before opening the manhole covers; three hooks end have different configurations.



Configuration 1: with flat drill bit hook to clean and scrape.



Configuration 2: L - shaped end for scraping in the inside of the slot and release the rotation for opening the lid.



Configuration 3: "T" shaped end to be used as a flap or insertion key in the slots.



Configuration 4: use in synergy with a choke belt for lifting operations



TECHNICAL CHARACTERISTICS

Code		K0272
Weight	Kg	0,5
Dimensions tool	cm	27 x 27 x 27

ES 1

SCREW EXTRACTOR FOR THE RELEASE OF BLOCKED AND OXIDIZED MANHOLES

Safety aid that avoids dangerous hammering to unlock lids or manhole covers blocked by inactivity, rust, scale or deformation.

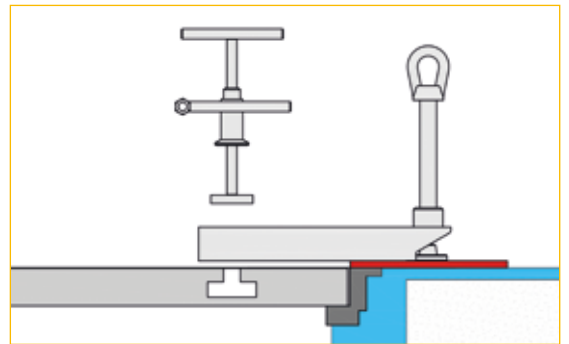

Phase 1. Insertion of the mechanical hook into the appropriate slot.

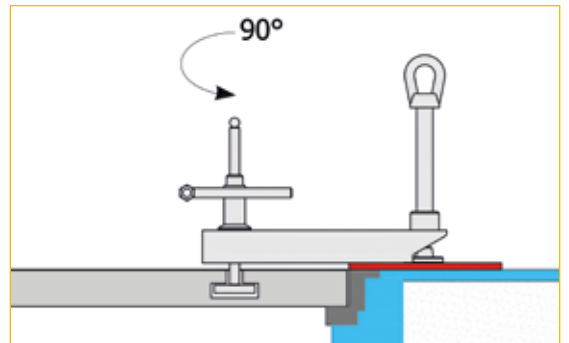

Phase 2. Rotating the mechanical hook and locking it.

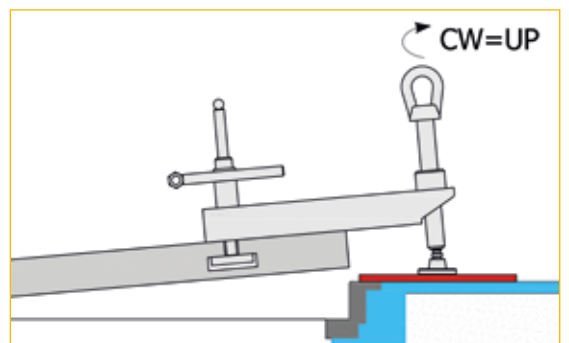

Phase 3 The clockwise rotation of the screw allows the initial release and unblocking of the lid.

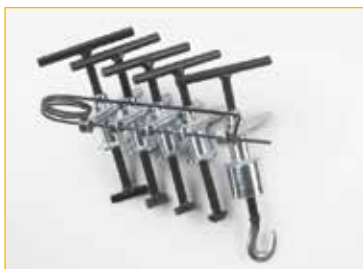

Use with ITALIFTERS mechanical hooks.

TECHNICAL CHARACTERISTICS

Code	K0278	
Weight without clamp	Kg	2,3
Length	cm	30

ANTI-FALL SAFETY APPARATUS FOR OPEN MANHOLE

A simple and effective system designed to prevent people, tools, materials from falling into the opening of UNCOVERED manhole.



Easy and simple positioning.



Sliding and adjustable struts at the tip of the arms to keep the cross in the correct position.



Self centering and folding metal grate.
Can hold up to Kg 200 without deformation.



Inspection site opened



TECHNICAL CHARACTERISTICS

Code	K0368	
Weight of the cross	Kg	8
Weight of grille	Kg	7
Dimension of grille open	cm	90 x 90
Dimensions protectable open area	cm	90 x 90

Modern high visibility extensible safety barrier designed to ensure maximum ease of transport and use in the reporting of road works and access closure.



The vivid orange color and the reflective bands guarantee higher visibility.



Ideal also for inside safety sites.



Easy and quick installation.



Transportable manually, effortlessly, even in urban areas with limited traffic.



Ideal in quick and multiple operations.

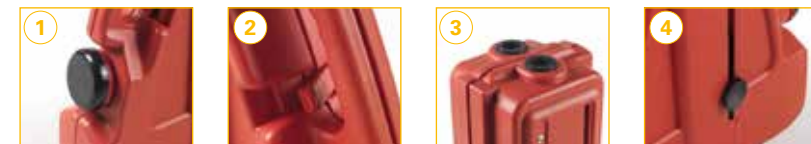

(1) Nozzle for water or sand (2) Locking for transport (3) Holster for insertion of safety signs or luminous bulbs (4) Locking knob when in extension

TECHNICAL CHARACTERISTICS

Code	K0270	
Dimension completely folded	cm	47 x 13 x h 107
Dimension in complete extension	cm	230
Width	cm	13
Weight dry	Kg	6,5
Weight full of water	Kg	14

SAFETY PLASTIC GATE WITH SQUARE OR LINEAR CLOSURE

Practical, very compact and light security gate ideal for signaling and securing open manhole area during maintenance work on underground networks and services.



Very practical, it starts and folds up in seconds.



The absence of sharp edges avoids accident.



Light and stable, it is easily transportable when folded.



Adhering to the road code contemplated in the DPR 12/16/1992 n.495 and subsequent modifications.



Use as an unfolded linear barrier.



Snap closure clip.



Locking and joining pin on sides.

TECHNICAL CHARACTERISTICS

Code	K0322	
Side dimension (in square closure)	cm	75 x 100
Height	cm	100
Weight (of the basic module of 4 elements)	Kg	8
Weight of one side element	Kg	2
Dimension packed	cm	75 x 100 x 8
Material	HPDE high density polyetilene	
Max linear extension (of 4 elements module)	cm	300

INFORMATIONS AND BASIC SAFETY

The manhole covers on the streets have hundreds of shape, different weights and conditions of placement. The opening of a manhole cover requires a series of technical, operationa effort and workers safety.

For safety reasons governed by current legislation (Legislative Decree 81/08 for the handling of loads consolidated text on ISO 11228 safety. Ergonomics - Application document for ISO standards on manual handling ISO 11228-1-2-3) operators must not manually lift more than 25 kg.

The **ITALIFTERS** line complies and provides the employer to satisfy and minimize the risks deriving from the manual handling of loads as required by article: 168 com. 2 - com. 3 of Legislative Decree 8108 and S.M.

The **ITALIFTERS** line products is the most complete and versatile on the market today and in line with all the above rules proven by numerous tests in difficult and demanding conditions . The traditional old dangerous system of opening with hammer and pickaxe can solve only a few manholes and almost never in line with the safety legislation.

The 5 maneuvering operations of the mandole:

The following standards are provided to describe and avoid the most common improper and dangerous opening manhole covers. Since it is impossible to foresee all dangerous situations, the rules do not guarantee total safety, therefore it is always a matter of using the most caution in all circumstances. Work inside the manholes must be done by trained, responsible personnel who knows how to work safely.

Work on pressure pipes, electrical cables, sewer pipes and generally works inside manholes can hide unpredictable dangers, this manual cannot be considered a complete course for safety.

In case of doubts do not risk but ask your supervisor

Operations:

To start, prepare a small intervention plan, foreseeing dangers and drawbacks, after the lid is removed, positioning it in a safe place. Always carry out the operations carefully to avoid accidents and injuries.

Almost always a lid that has not been moved for some time requires a lifting effort greater than 25 kg: if possible, avoid lifting higher weights than what is prescribed by the accident regulations.

1 - Preparation and signalling of the site and ongoing operations

The site and the operation area must be appropriately reported as required by law with signaling barriers, which protect from traffic and avoid the close presence of curious. Provide a suitable large work area to allow good operation and prevent operators from walking too close to the lid opening. If the opening is left uncovered for the time of breaks or interruptions, it is essential to cover it with suitable anti-fall equipment. Keep objects and tools away from the edges of the opening to avoid their involuntary dangerous falls inside



2 - Typing the lid and cleaning the joints

Cleaning the joints from possible materials that cause the locking by typing using the **MZ120** or with the **ES1** screw extractor and clean the surface in order to remove any residue and allow adequate adhesion of the lifting magnets.

For mandole with slot locks use the inserting clamps or hooks for mechanical lifting, cleaning can be done with the specific tool **ITALIFTER T3 POLYTOOL**, a hard steel tool with three rostrum tips that allow a quick break of the encrustations inside the slots

3 - Locking / hooking the cover

There are two possible locking modes:

Magnetic locking with adequate contact of the magnet with the lid surface.

Mechanical locking by hooking the slots or the openings of the lid with wing and hook locking systems.

4 - Lifting / moving the cover

The operation must be carried out with caution and attention and only after making sure that the cover is adequately blocked by magnets or mechanical hooks.

If the lid, which has not been operated for some time, requires a lifting effort of more than 25 kg, it is advisable to free the lid from incrustations and unlock (if present) the safety bolt. Beyond this it is always advisable to carry out the lifting by two operators to avoid harmful efforts for the operator.

It must also be ensured that the lid is lifted vertically. When lifting very heavy lids, it is recommended to lift, lay and then drag it.

5 - The relocation of the cover

To replace the cover, you can use the wheeled lever or you can drag it into position ensuring its support.

Make sure that manhole joints or keys slot that require to be centered are in place and locked. Always lift with vertical movements for adequate adhesion of the magnets.



TRIME GROUP

Lighting Tower



Power Division



Water treatments



Fuel tanks



Dust Suppression



Hydraulic Tools



Lifting Tools





Registered office: 22060 NOVEDRATE (CO) - Italy - Via Cortiva, 5
Operational headquarters: 22066 Mariano Comense (CO) - Italy
Via Sant'Agostino 158 - Tel. +39 031 792 040

info@doa.it
www.italifters.com - www.doa.it

 **TRIME GROUP**